

# Installation & Operation Instructions

# THE **PRO**PANEL™

## Universal Zone Control



Find the latest version of this manual at [www.arzelzoning.com/pro-panel](http://www.arzelzoning.com/pro-panel)

Download the Arzel Pro™ mobile app for installation and setup



Arzel Zoning Technology, Inc.  
4801 Commerce Pkwy.  
Cleveland, OH 44128

Ph: (216) 831-6068  
Fax: (216) 831-6074

[www.arzelzoning.com](http://www.arzelzoning.com)

©2026 Arzel Zoning Technology



### Tech Support

Call toll-free (800) 611-8312  
8am–9pm EST, 7 days a week  
[techsupport@arzelzoning.com](mailto:techsupport@arzelzoning.com)

### Warranty Information

[www.arzelzoning.com/warranty](http://www.arzelzoning.com/warranty)

## Thank you for choosing Arzel!

Thank you for choosing the Arzel® Pro Panel™ zoning system for your comfort and energy efficiency needs. The Pro Panel represents the latest in zoning technology. It is designed to both enhance your system's performance and deliver just the right amount of heating and cooling to every area of your home or building.

Please be assured that in addition to having the highest in product quality, we are committed to unparalleled product performance and complete customer satisfaction.



## Homeowner's Guide

Your zoning system is simple to operate and requires no maintenance. The system will allow you to increase your comfort by directing conditioned air to separate areas (zones) based upon each zone's thermostat setting. It provides the opportunity to conserve energy by adjusting the thermostat setting in unoccupied areas to energy saving levels.

### System Operation

To operate the system, just set or program each zone's thermostat to your desired comfort and/or setback settings. When there is a call for heating or cooling from any zone, the appropriate heating or cooling equipment will be turned on. The dampers in zones not requiring heating or cooling will close and the conditioned air will be directed to the calling zone(s) until the thermostat is satisfied.

### Thermostat Priority

The system responds to each thermostat on a first-call, first-serve basis unless your contractor has programmed an alternate priority approach to deal with concurrent heat and cool calls with your application. The system can be set to an Automatic Priority (first-call/ first-serve), Heat Priority, Cool Priority or a Zone Weight Priority setting. Please refer to page 18 or consult your contractor for more details regarding the priority option programmed for your system.

### Fan Operation

When there is not an active call for heating or cooling, you may circulate air in individual zones by selecting the "Fan ON" function on each individual thermostat. The dampers in zones with the fan set to "Auto" will close.

### To Get More Information

Please feel free to learn more about the installation and operation of the Arzel Pro Panel by reviewing this entire manual. Consult your installing contractor with any questions regarding system operation. If questions are still unresolved, you may call Arzel's Technical Support for homeowners from 8am–5pm EST, Monday–Friday. Please have your panel serial number available when you call. (See back cover for location information.) Your installing contractor can reach Arzel Technical Support 7 days a week, 8am–9pm EST. The Arzel Technical Support phone number is 1-800-611-8312.

## Table of Contents

Topic	Page
Product Overview .....	4
General System Operation .....	4
Installation Precautions.....	5
Board Layout.....	6
Installation and Setup Instructions.....	7
Wiring Diagrams .....	8
SAT and OAT Sensor Installation .....	10
How the Sensors Operate .....	11
Pump Operation.....	12
How to Temporarily Stop Zoning.....	12
Zone Weight Calculation .....	13
The Arzel Pro Mobile App .....	14
Connecting to the Pro Panel.....	15
Daisy Chaining Pro Panels.....	15
A2L Mitigation Wiring.....	17
Emergency Heat Mode.....	18
Error Notifications .....	18
System Commissioning.....	19
Pro Panel Settings.....	21
Setup Worksheet.....	26
EzySlide® Damper Installation .....	27
Warranty Information and Procedure.....	back cover
Bypass Sizing Charts.....	back cover

## Zoning System Layout

Zone	Tube Color	Total # of Dampers	Thermostat Location
1			
2			
3			
4			

## Product Overview

The Pro Panel is a non-proprietary, residential and light commercial zoning system, designed for standard heat/cool or heat pump control. Innovative features provide the opportunity to customize the control to meet the needs of any forced air system and maximize its efficiency and effectiveness.

### Mobile App Guided Setup

The Pro Panel can be configured, commissioned, and tested using the Arzel Pro mobile app. The Pro Panel connects to a tablet or mobile device via Bluetooth to display settings and system status information directly on the mobile app screen. The mobile app provides a guided setup process and serves as a diagnostic tool for evaluating system operation.

### Proactive Staging

The Pro Panel will automatically “stage-up” using an advanced staging algorithm based on adjustable timers and target temperatures. The user will not have to wait for the temperature in the zone to fall or rise before the HVAC equipment reacts. This feature eliminates the need for two-stage thermostats.

For heat pumps and electric heat strips, the Pro Panel monitors the supply air temperature (SAT) and outdoor air temperature (OAT) to determine which heat stage to run.

### Staging Based on Zone Weight

The air handler or blower Y1/Y2 “stages” independently from the condenser Y1/Y2. Two sets of Y1/Y2 contacts are located on the board for this purpose. Zone weight staging reduces or eliminates the need for a bypass by disabling the W2 and Y2 blower outputs when the available ductwork is limited.

### Broad Thermostat Compatibility

The Pro Panel is compatible with any conventional 24VAC thermostat including wireless, auto/manual changeover, programmable and non-programmable. Zone 1 will accept any heat/cool or heat pump thermostat. A heat pump thermostat can be used on zone 1 to provide convenient control of emergency heat. Zones 2-4 must use standard four or five wire single-stage heat/cool thermostats only.

### Humidification and Dehumidification

With the addition of a simple humidistat, the Pro Panel can control 24VAC humidifiers; a solenoid and damper can be added for controlling airflow through a bypass humidifier. It can also operate the system similar to a whole house humidifier.

By adding a dehumidistat to zone 1, the panel can optionally output for G to the blower and Y1 to the condenser for an adjustable period of time when no active calls are being served. The HVAC output D can be connected to the 24VAC DEHUM terminal on the furnace to activate the dehumidification blower profile.

### Additional Built-in Controls

- Full function dual-fuel control
- Supply Air Temperature settings (High/Low) provide equipment protection at reduced CFM operation and stage down capacity control.
- Outdoor Air Temperature sensor provides an outdoor reset function, balance point control, auxiliary heat lock out and low ambient cooling lock out.

## General System Operation

A call from any zone thermostat will initiate HVAC equipment operation and position the solenoid air valve to open the damper(s) for its zone. The mini pump is energized to automatically activate the dampers, either open or closed, as required. Vacuum opens the dampers and pressure closes the dampers. When a call is satisfied, dampers

are held in place for two minutes. This will allow the residual conditioned air to be delivered into the last zone satisfied. The adjustable Secondary Purge Time (0 to 180 seconds) will continue to operate the pump to open all the zone dampers for a soft start on the next cycle.

## Installation Precautions

**Read these instructions carefully. Failure to follow them could damage the Arzel zoning system and/or cause a hazardous condition.**

### Warning

1. Disconnect the power supply to the HVAC system and the zoning system before making any wiring connections to prevent the danger of electrical shock or equipment damage.
2. Be sure the HVAC manufacturer's operating specifications are compatible with the Arzel zoning system.
3. All wiring must comply with applicable electrical codes, ordinances and regulations.
4. Use properly grounded tools, safety glasses and gloves when drilling or cutting sheet-metal ducts, fiberglass or any hard objects.

### Caution

1. The Arzel system is designed for indoor use only.
2. You must touch a grounded metal object before handling the control panel to avoid potential damage due to electrostatic discharge.
3. Install the system in a semi-conditioned space between 40°F and 140°F in a non-condensing area.
4. Check all system operations after installation is complete.
5. The damper blade gently wipes the inside of the ductwork. Insert a sleeve inside any fiberglass, or abradable ductwork, so the blade does not abrade the materials into the air.
6. Leave these instructions with the installed system for future use.
7. There are both AC and DC terminals on the circuit board. Do not intermingle wires.
8. The purpose of the SAT (Supply Air Temperature) control is to function as an "operating limit". When set per the instructions, the SAT control will add additional capacity control and prevent the equipment from operating outside the OEM's specifications.

### Warning



This product can expose you to chemicals known to the state of California to cause cancer and birth defects or other reproductive harm. For more information go to: [www.P65Warnings.ca.gov](http://www.P65Warnings.ca.gov)

# Board Layout

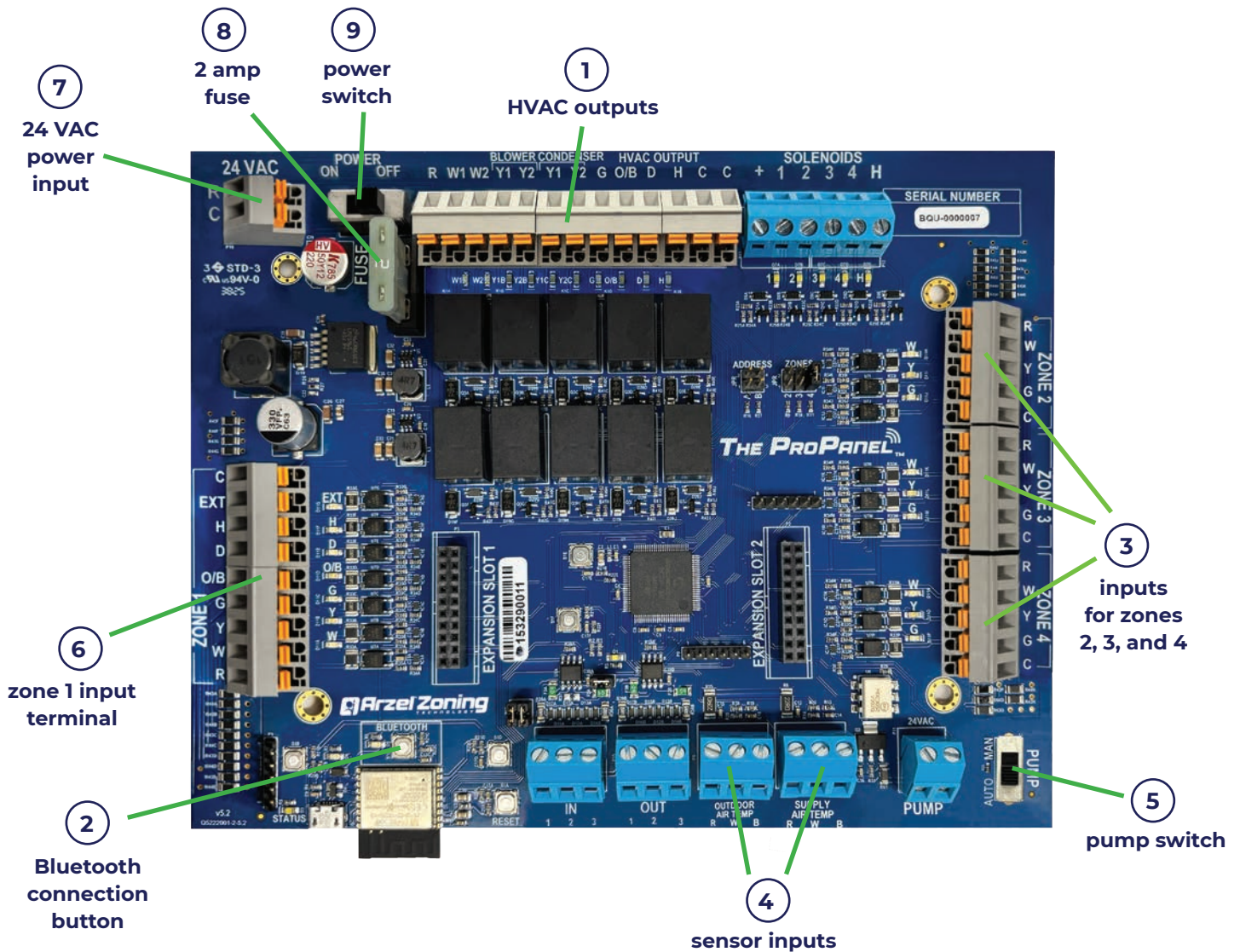

Item #	Description	Function
1	HVAC outputs	Dry contacts to control HVAC equipment
2	Bluetooth connection button	Puts the board into Bluetooth connection mode
3	Zone 2 through Zone 4 inputs	Four or five-wire thermostat inputs (heat/cool thermostats only)
4	Sensor inputs	Connections for Supply Air Temperature (SAT) and Outdoor Air Temperature (OAT) sensors
5	Pump switch	Auto/manual switch for the pump
6	Zone 1 input terminal	Inputs for any 24 VAC thermostat, heat pump or heat/cool
7	24 VAC power input	Arzel plug-in transformer connections R and C
8	2 amp fuse	Protects the board against thermostat wiring shorts
9	Power switch	Controls 24 VAC power source to zone control panel

# Installation and Setup Instructions

## 1. Install Dampers and Run Tubing

Dampers install directly into new or existing ductwork. Orient the tube connection port so it is pointing up-stream (toward the equipment). Install one main tubing run for each zone. Use connection tees for multiple dampers in a zone. Arzel recommends using a different color tube for each zone.

**Dampers should not be concealed behind a permanent barrier such as drywall without an access panel.**

## 2. Mount Control Panel

The control panel must be mounted vertically in a non-condensing, semi-conditioned area where temperatures will not normally exceed 140°F. **Do not mount panel on ductwork, HVAC equipment, stairwell, or bedroom walls.** The best method is to attach a piece of ¾" plywood to an exterior stud wall or foundation. Hold the panel level on the wall and mark the positions of the upper mounting holes. Drive two screws into the wall leaving the heads at least ½" out. Set the panel over the screws. Drive two screws into the lower mounting holes. Tighten the upper screws. **Prior to making electrical connections, touch a mechanical ground to discharge static electricity.**

## 3. Connect Tubing

Connect the damper tubing to each of the zones at the top of the panel. The zone number is stamped next to each tubing port. Keep unused ports covered with the red caps.

## 4. Connect Thermostats

Install a thermostat for each zone observing terminal designations. Use 18-gauge, multi-conductor, solid thermostat wire to connect thermostats to the control panel. Zones 2, 3, 4 must be conventional heat/cool thermostats, even for heat pump systems. Document the location of each thermostat connected to the zones on the "Zone Layout" label on the side of the panel.

## 5. Connect Equipment

Use 18-gauge, multi-conductor, solid thermostat wire to connect the HVAC outputs located along the top of the zone control panel to the HVAC equipment. Connect Y1/Y2 Blower to the air handler/furnace controls and Y1/Y2 Condenser to the heat pump/air conditioner controls. The two C terminals are for connection between the furnace/air handler transformer and the common circuit of the heat pump/air conditioner controls.

## 6. Connect Transformer

Use 18-gauge, 2-conductor solid wire to connect the R and C power input terminals to the mounting screws on the 40 VAC self-resetting, plug-in transformer supplied with the Arzel Zoning system. Plug in the transformer to any standard 120 VAC receptacle. **If you elect to not use the provided transformer, your warranty may be void. Additional surge protection is recommended.**

## 7. Connect Sensors

- Install the Supply Air Temperature (SAT) sensor in the supply duct 12 to 18 inches from the plenum and before any dampers.
- Install the Outdoor Air Temperature (OAT) sensor outdoors, preferably on the north side of the house, not in direct sunlight.
- Wires must be connected to corresponding terminals, R-red, W-white and B-black.

## 8. Turn on Panel and Connect

Flip the panel's power switch to turn it on. The panel will be in pairing mode so you can connect to the Arzel Pro mobile app. Press connect in the app to connect, then follow the instructions to set up your system.

# Wiring Diagrams

## Conventional Heating/Cooling

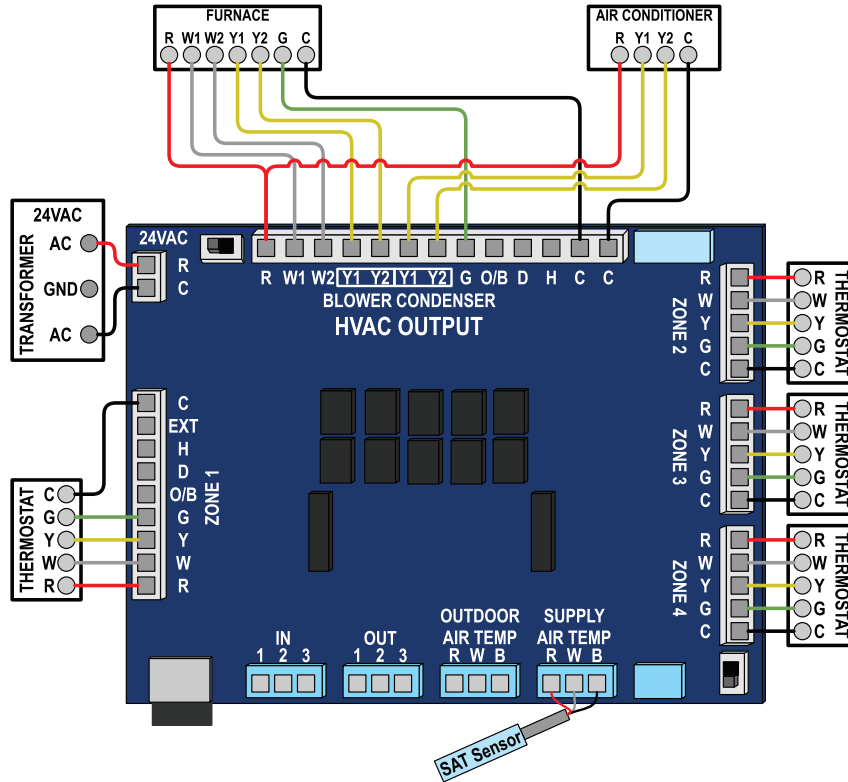

## Heat Pump with Conventional Thermostat at Zone 1

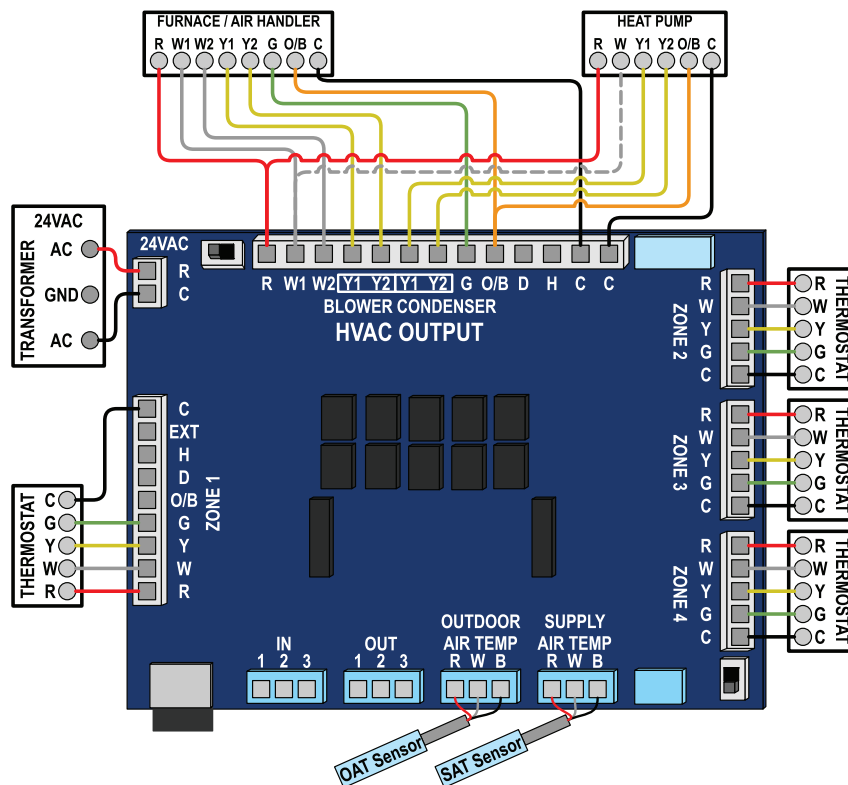

# Wiring Diagrams (continued)

## Heat Pump with Heat Pump Thermostat at Zone 1

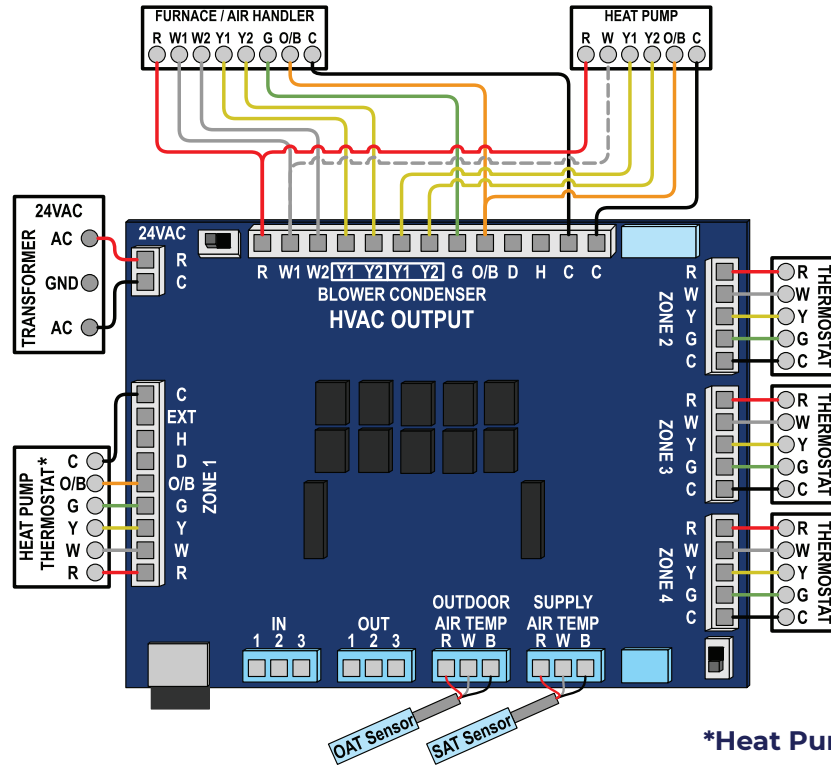

\*Heat Pump thermostat is not required

## Package Unit / Package Heat Pump

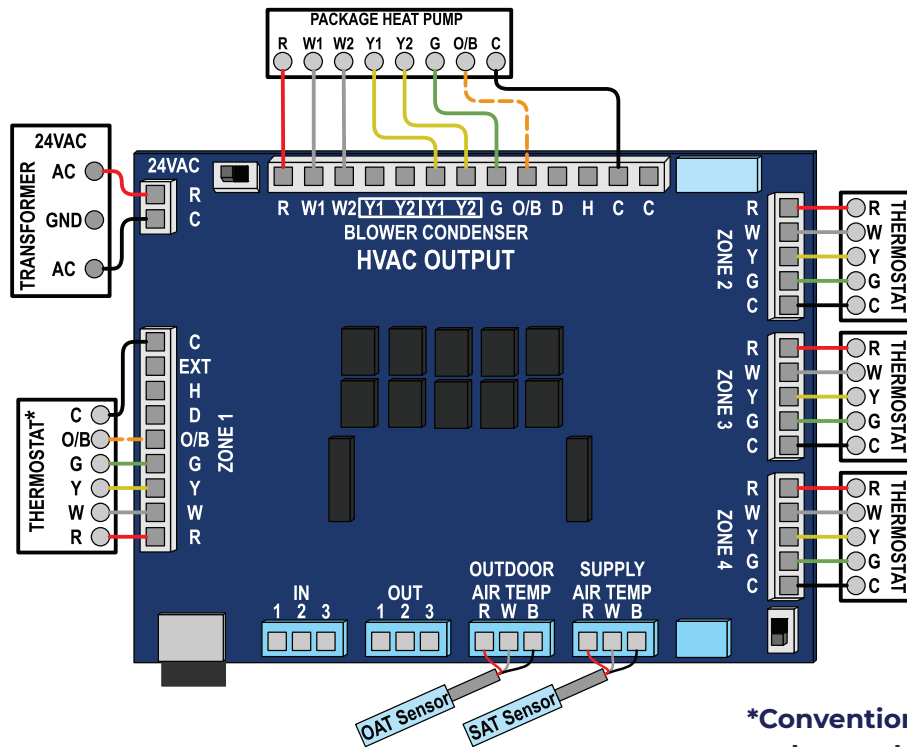

\*Conventional thermostat can be used for heat pumps

# SAT and OAT Sensor Installation

## Sensor Installation Notes

- Both sensors are identical and can be used as either the Supply Air Temperature (SAT) or Outside Air Temperature (OAT) sensor.
- If additional wire length is required on a sensor, up to 50 ft of 18-3 thermostat wire can be added.
- Keep panel power “off” while connecting sensors to the board.
- The sensors have three conductors, (red, white, black) and must be wired to the appropriate (R, W, B) terminals at the sensor connection.

## SAT Sensor Installation

The sensor must be located in the supply trunk, downstream of the heat exchanger and cooling coil and before any trunk dampers.

Do not locate the sensor in an area that is in the direct line of sight of the heat exchanger, cooling coil or UV Lights. These locations can cause false readings.

You'll find a sensor bushing in the box with the Pro Panel, which you can use to protect the sensor and hold it in place in the duct.

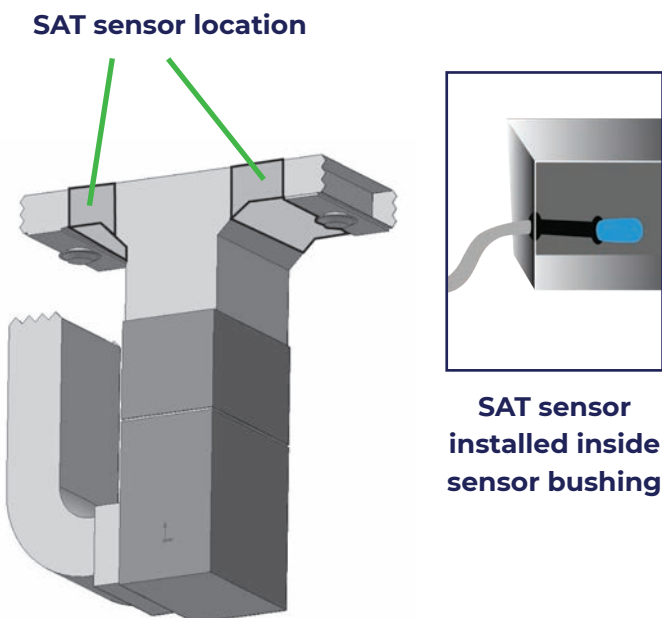

## OAT Sensor Installation

1. Choose a location:
  - Out of direct sunlight
  - Above maximum snow level
  - That is accessible should service be required
  - Preferably on the north side of the house
2. Drill a 5/16" access hole through the exterior wall aligned with one of the pre-drilled holes on the back of the enclosure body. If the sensor wire is to run along the outside of the structure, use opening located at the bottom of the enclosure.
3. Mount the sensor enclosure level over the access hole with the sensor opening on the back plate aligned with the 5/16" opening.
4. ALTERNATIVE SENSOR MOUNTING
  - Sensor can be mounted inside the control section of the outdoor condensing unit.
  - Ensure sensor is mounted in a location where its temperature reading will not be influenced by the equipment
  - Route the sensor lead into the sensor enclosure and fasten with the provided wire tie.

*An OAT sensor enclosure is provided to protect the outdoor sensor from physical damage as well as snow, ice and solar heat influence.*

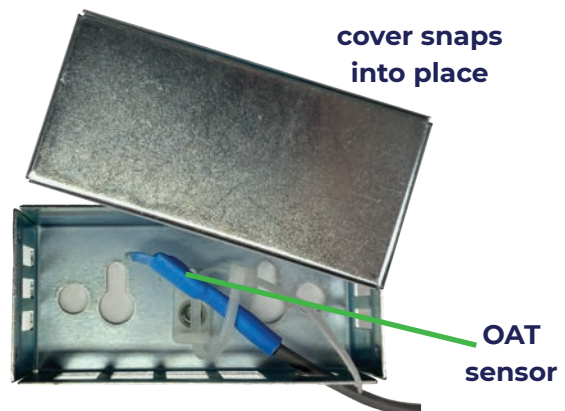

## How the Sensors Operate

The Pro Panel uses both Supply Air Temperature (SAT) and Outside Air Temperature (OAT) sensors to protect the HVAC equipment and proactively choose the most appropriate mode of operation.

The Decision Points in the table below are all adjustable through the Arzel Pro mobile app. The installer is responsible for choosing appropriate staging settings.

The Pro Panel will stage up as required to maintain the amount of cooling or heating that is needed by the space based on the SAT and the OAT. It will stage the blower (multi/variable speed motors) according to the Zone Weight of the ductwork being served.

### High and Low Limit Protection

There are adjustable high temperature limits for heating, and low temperature operating limits for cooling. For dual-fuel and all-electric systems, there are two separate high limits, one for the heat pump and one for the backup heat.

The SAT ensures that the HVAC equipment will always be operated inside the OEM specifications. The SAT functions in a staged-manner: As soon as the SAT exceeds the operative limit, the equipment is staged down. If the SAT stays outside acceptable limits for two minutes, then it will cycle off the equipment, leaving only the fan running.

### Proactive Staging

The Pro Panel can handle up to four stages of heating (two-stage heat pump with two stages of electric heat strips or two stages of gas furnace operation). It handles two stages of cooling. The Pro Panel manages all staging with single stage inputs from all thermostats.

Staging is managed by continually comparing the SAT to field adjustable target temperatures. If the system is not maintaining the appropriate temperature then it will automatically stage up. The table below outlines how the system stages.

HVAC Equipment	Decision Point	Function
Heat Pump Heating	Heating SAT Target	Minimum acceptable temperature in the plenum. If the system cannot maintain this temperature then it will automatically stage up.  Note: If the OAT drops below 30°F, this target temperature rises 1°F for every 2°F below 30°F. This causes the system to stage more aggressively on colder days.
Heat Pump or A/C Cooling	Cooling SAT Target	Maximum acceptable temperature in the plenum during cooling. If the system cannot maintain this temperature, then it will stage up cooling automatically.
Fossil Fuel Furnaces and Auxiliary Heat Strips	W2 Zone Weight Threshold	For auxiliary heat or furnace operations, the system stages up and down based upon the served zone weight. If the system is serving more zone weight than the W2 Zone Weight Threshold it will stage up. If it is serving less weight then it will stage down.
Condensers and Multi/Variable Speed Blowers	Y2 Zone Weight Threshold	Airflow with multi/variable speed systems is controlled based upon the served zone weight. If the system is serving more zone weight than the Y2 Zone Weight Threshold it will stage up. If it is serving less weight then it will stage down.

## Pump Operation

### Air Pump Operation

The air pump will start any time there is a call for heating, cooling, or fan operation. After the call ends and the HVAC equipment turns off, the pump will continue to run for two minutes plus the “Secondary Purge Time” delay. This gives the system time to purge the air remaining in the ductwork, and allows for all dampers to open to provide a soft start to the next call. The air pump is designed for continuous operation and can control up to 35 damper actuators.



### Pump Switch

The pump switch (pictured below) is provided to test the damper system and to bypass the zoning system in case of a board emergency. This switch will start the pump manually and with the power switch in the OFF position, all the zone dampers will open. This will aid in troubleshooting by allowing the operation of the HVAC system independent of the Arzel panel, if you suspect a circuit board failure.

## How To Temporarily Stop Zoning

### You can bypass the zoning system by following these steps

1. Turn the Arzel power switch off. You must keep this switch in the OFF position to prevent zone thermostats from calling for service and to place the zone dampers in the open position.
2. Disconnect the wires from any one zone thermostat terminal and connect them to the HVAC Output terminals.
3. Turn the pump switch to manual (MAN) position.

The HVAC equipment will now be controlled by the one thermostat connected to the HVAC Output terminals. The pump will run continuously, holding all zone dampers open.

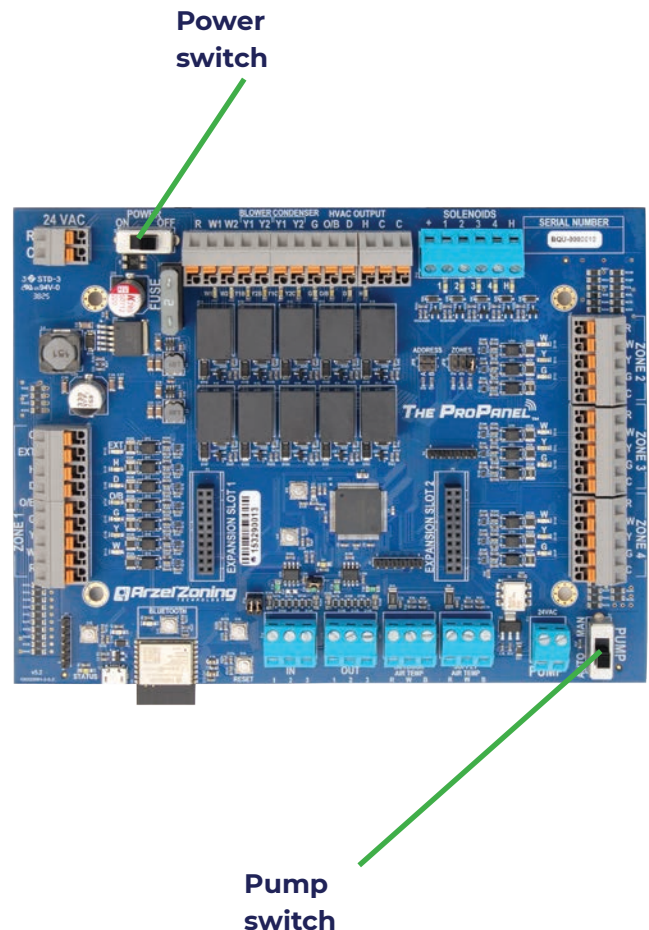

# Zone Weight Calculation

The following is an example of Zone Weight set-up to demonstrate the functionality behind the settings you choose.

This application is a two story home being served by four independent zones. The zone weights are determined by simply dividing the number of runs in each zone by the total number of runs in the system. Total zone weight does not need to add up to 100% and may, in fact, be over or under weighted to produce the desired results.

- Zone 1** Living area, first floor..... (5 six-inch runs / 20 = 25%)
- Zone 2** Living area, first floor..... (6 six-inch runs / 20 = 30%)
- Zone 3** Master suite, second floor..... (4 six-inch runs / 20 = 20%)
- Zone 4** Bedrooms, second floor..... (5 six-inch runs / 20 = 25%)

**Total: 20 six-inch runs**

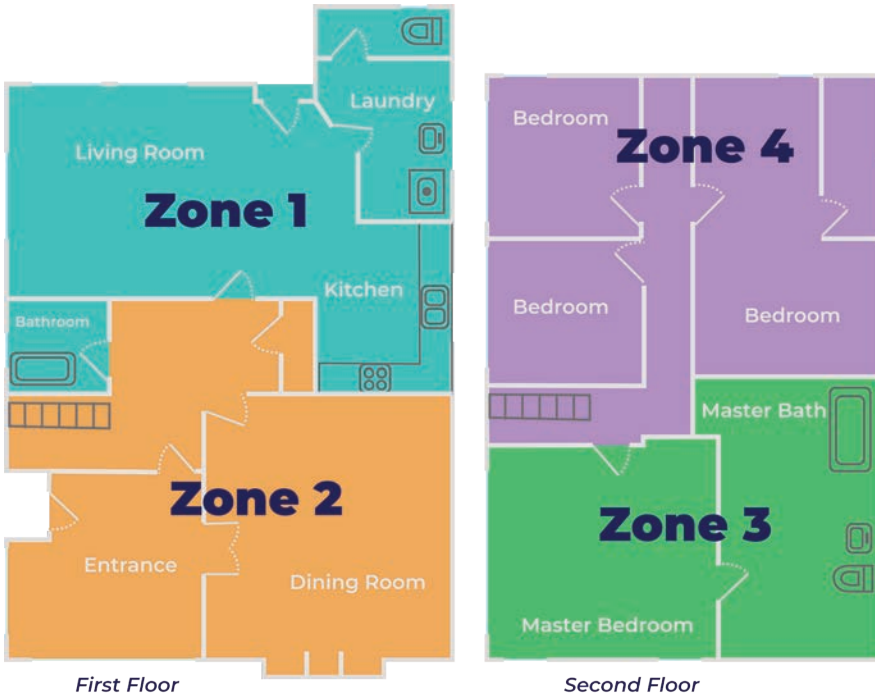

**Handling Small Zones**

For some applications, you may want to design a zone that's too small to handle the equipment load when it's calling alone.

You have the option to set a small zone as a slave. A slave zone will only open the dampers when another zone is already being served. This way, the small zone will never receive the full equipment load. An additional zone will always be engaged before the small zone is served.

A small zone can be configured this way in the Zone Weight setting.

Y2 Blower (high stage fan) Y2 Condenser, (high stage compressor) and W2 (high stage heating) will not be engaged unless the accumulated, served zone weight is equal to or greater than the "Y2 Zone Weight Threshold" or "W2 Zone Weight Threshold", respectively.

Zone Weight settings should provide maximum airflow to zones calling, without creating objectionable air noise at the registers. Since many systems serve a single zone the majority of the time, low stage energy savings will be achieved.

Threshold Set-Point	Stage-up can occur when...
100%	All 4 zones call together
80%	Zones 1, 2, and 4 call together
70%	Zones 1, 3, and 4 call together
55%	Zone 2 with either 1 or 4 call together

# The Arzel Pro Mobile App

## The Dashboard

The Arzel Pro mobile app is your portal to customizing and troubleshooting your zoning installations. The set-up options allow you to design the control sequence in the best interest of your customer, balancing energy usage with comfort delivery while maintaining safe equipment operation. The Pro Panel dashboard provides an overview of the system state, displaying calls from each of the zone thermostats, temperature sensor readings, and the signals sent to the HVAC equipment.

The screenshot shows the Arzel Zoning Technology mobile app dashboard. At the top, it displays the system state as 'Cooling 07m31s'. Below this, there are 'HVAC Outputs' including W1, W2, Y1 BLW, Y2 BLW, Y1 CON, Y2 CON, G, O, D, and H. The OAT (Outdoor Air Temperature) is 87°F and SAT (Supply Air Temperature) is 57°F. Condenser Lockouts for Y1 CON and Y2 CON are shown as '--'. The 'Zones' section shows '25% Served' and a list of four zones with their respective thermostat inputs (W, Y, G) and damper status (Served/Not Served) and served time (07m31s, 00m00s, 00m00s, 00m00s). The bottom navigation bar includes icons for Dashboard, System Configuration, Resources and Help Documents, and App Settings.

**Energized output(s) to equipment**

**System state and runtime**

**Outputs to furnace or air handler**

**Outputs to condenser**

**Outdoor Air Temperature (OAT)**

**Supply Air Temperature (SAT)**

**Sum of zone weights for served zones**

**Compressor stages in a timed off cycle**

**Zone weight**

**Zone thermostat inputs**

**Zone served time**

**Damper open/closed indicator**

**Zone status**

**Dashboard**  
View the system status, check thermostat inputs and HVAC outputs

**System Configuration**  
View and edit the Pro Panel HVAC equipment settings

**Resources and Help Documents**  
Access online resources or contact Arzel Tech Support

**App Settings**  
Switch between Fahrenheit and Celsius, update the Pro Panel, or enable demo mode

**System Logs**  
Download the system logs to view the runtime history

App screens and menu options may vary depending on app version and system configuration. Always use the latest version of the app. You can find the latest version of this manual at [www.arzelzoning.com/pro-panel](http://www.arzelzoning.com/pro-panel).

## Connecting to the Pro Panel

### 1. Download the Arzel Pro mobile app

Scan the QR code below using the camera on your phone or tablet, then download the Arzel Pro mobile app to your device.



### 2. Accept app permissions

Open the Arzel Pro mobile app and accept permissions to allow the app to connect via Bluetooth



### 3. Power on the board, or press the Bluetooth button

Bluetooth pairing begins automatically when the board is turned on. It can also be started manually or by pressing the "BLUETOOTH" button; the blue light will flash during pairing mode

**Bluetooth connection button**

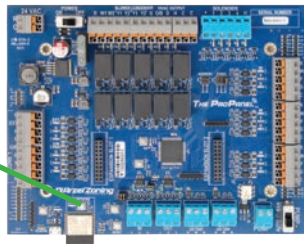

### 4. Connect

The Pro Panel will appear in the list of devices on the Arzel Pro mobile app; tap the item in the list to connect

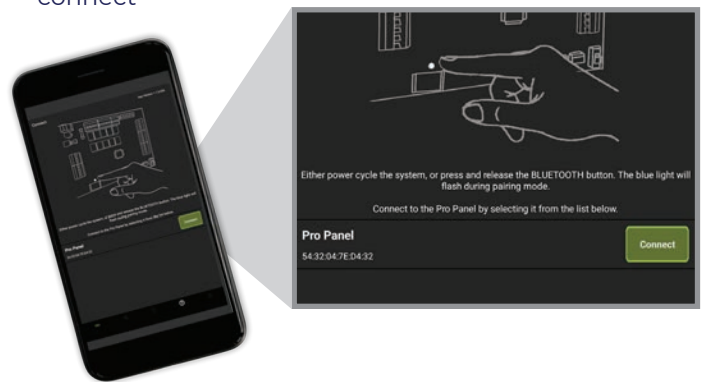

## Daisy-Chaining Pro Panels

You can connect multiple Pro Panels together to create a single zoning system with additional zones. Up to four panels can be connected, allowing up to 16 total zones.

### Jumpers

To daisy-chain Pro Panels, you'll need to configure each panel to have a unique address. The address is set by placing jumpers on the pins labeled ADDRESS, located above the Pro Panel logo. You will find spare jumpers near the bottom of the circuit board, above the IN terminal and to the right of the Arzel Zoning logo.

To add additional panels to your system, place the jumpers on each panel like this:

- Panel 1 – no address jumpers
- Panel 2 – place a spare jumper on the A jumper pin
- Panel 3 – place a spare jumper on the B jumper pin
- Panel 4 – place spare jumpers on both A and B jumper pins

When you're daisy-chaining more than 2 panels, there is another step. Find the jumper above the IN terminal, labeled here as "middle of the chain jumper pins."

For 3-panel systems, remove the middle of the chain jumper from the second panel.

For 4-panel systems, remove the middle of the chain jumper from the second and third panels.



**Address Jumper Pins**

**Middle of Chain Jumper Pins**

**Unused Pins with Spare Jumpers**

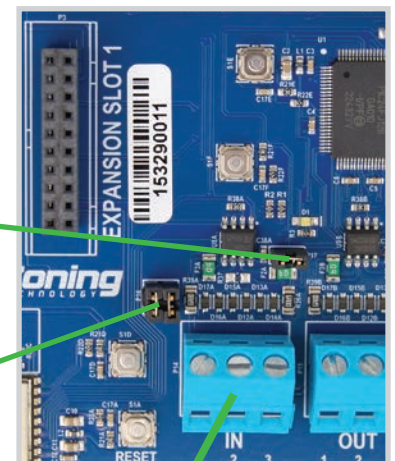

**IN terminal**

*(continued on the next page)*

## Daisy-Chaining Pro Panels (continued)

### Wiring and Jumper Placement

Use a three-wire bundle to connect multiple panels together. For each panel you add to the chain, wire the OUT terminal on the first panel to the IN terminal on the second panel, making sure the 3 wires correspond to the contacts labeled 1, 2, and 3.

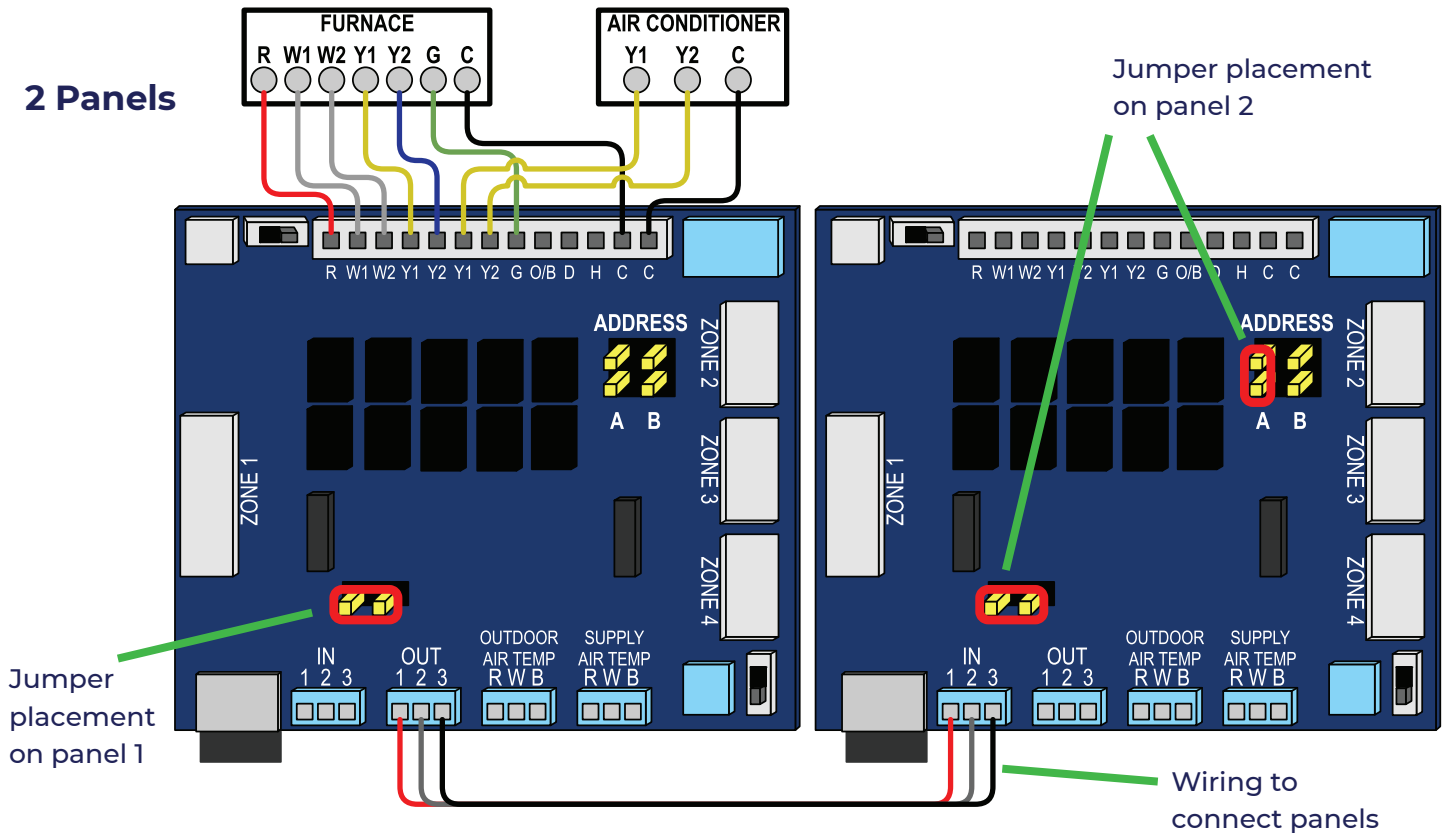

### 3 Panels: Wiring and Jumper Placement

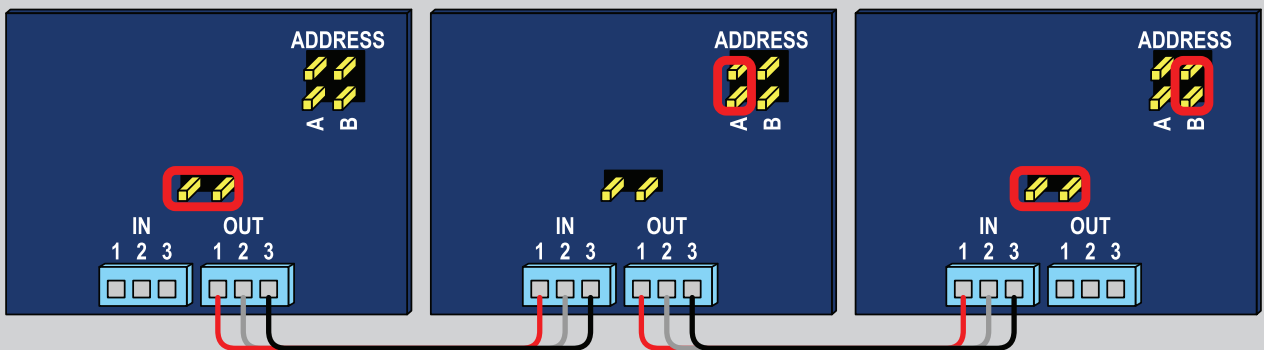

### 4 Panels: Wiring and Jumper Placement

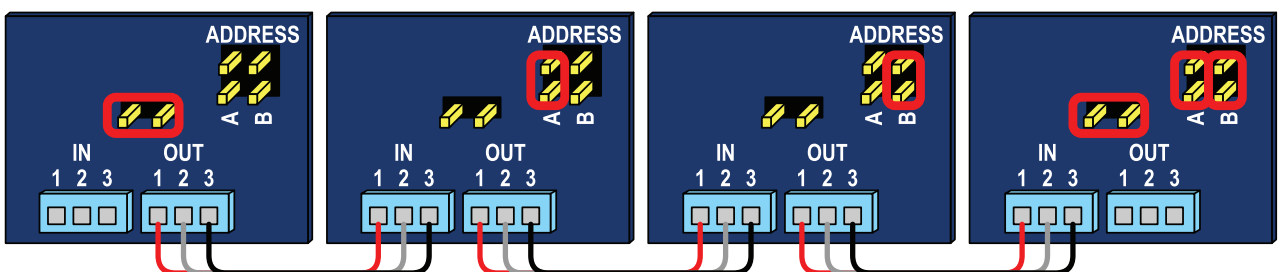

# A2L Mitigation Wiring

## How to Implement A2L Mitigation Wiring on the Pro Panel

The Pro Panel is designed to connect directly to an A2L mitigation board. If the mitigation board has dry contacts that open or close when there is a leak, you can wire those contacts directly to the R and EXT terminals at the zone 1 connection.

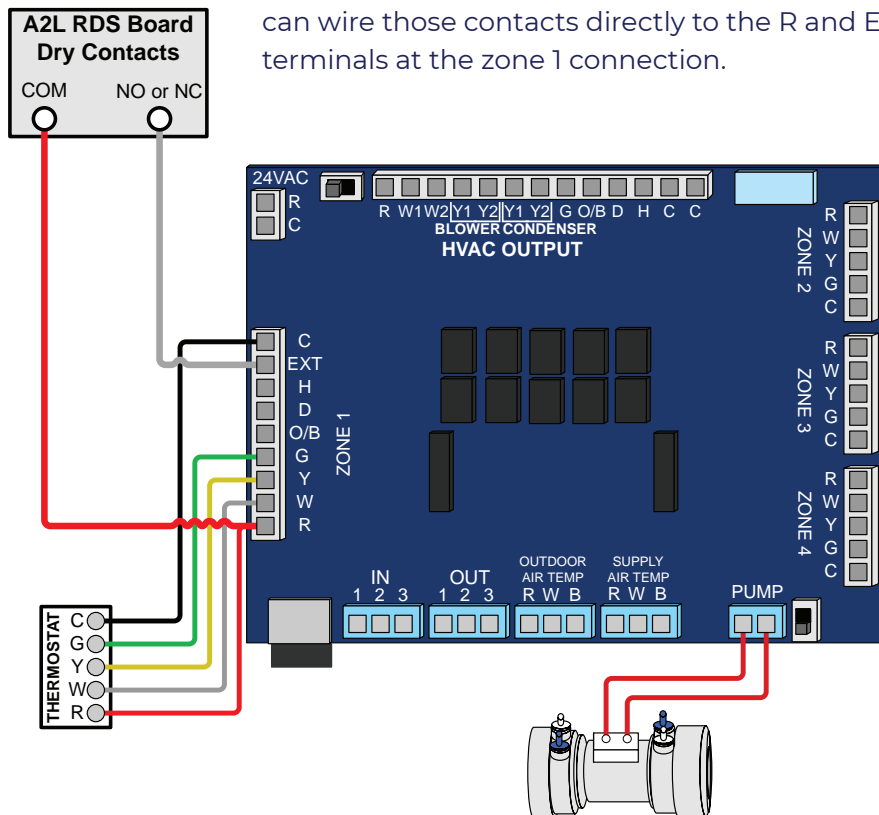

When the mitigation board signals that there is a leak, the Pro Panel will:

- Shut off the heating and cooling
- Turn on the fan in the highest stage available
- Open all dampers
- Flash the STATUS LED in the lower-left corner

## Configuring the Pro Panel for A2L Mitigation with the Arzel Pro App

The Arzel Pro app can be used to tell the Pro Panel if the contacts are normally open or normally closed. Navigate to the setting called “EXT Input During A2L Leak”. If the dry contacts close when there is a leak, select 24VAC. If the dry contacts open where there is a leak, select 0VAC.

Navigate to the setting called “EXT Input During A2L Leak”. If the dry contacts close when there is a leak, select 24VAC. If the dry contacts open where there is a leak, select 0VAC.

The Arzel Pro app dashboard will display a message if there is a leak.

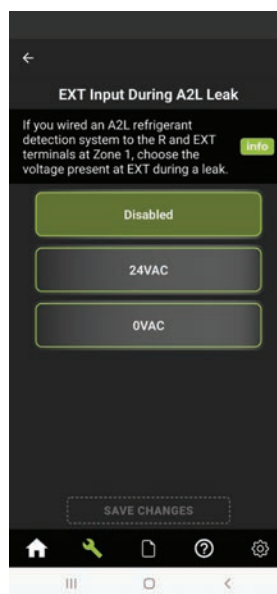

Setting Screen for EXT Input During A2L Leak

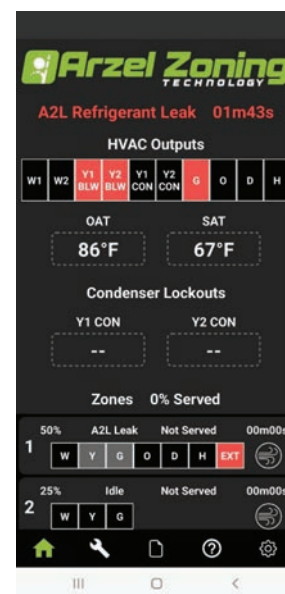

Arzel Pro app dashboard during an A2L leak

## Emergency Heat Mode

For dual-fuel and all-electric systems, an optional heat pump thermostat can be used at zone 1 to control emergency heat.

Whenever the heat pump thermostat at zone 1 energizes W without Y, the Pro Panel will respond by entering emergency heat mode.

In emergency heat mode, the Pro Panel will heat using only the backup heat source. Even though emergency heat mode is initiated from zone 1, the backup heat will be used to serve all zones until the Pro Panel exits emergency heat mode.

To exit emergency heat mode, the zone 1 thermostat must call for the heat pump to run, or call for cooling.

The Arzel Pro app will display text on the dashboard when the Pro Panel is in emergency heat mode.

**Arzel Pro app dashboard in Emergency Heat Mode**

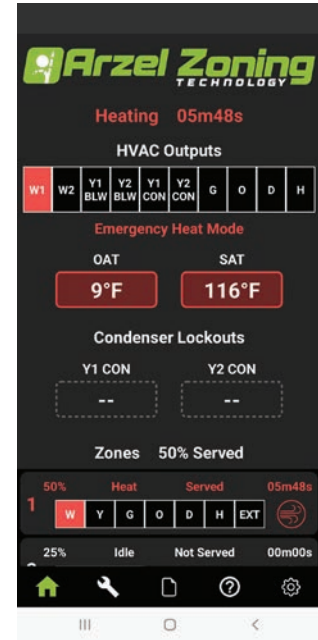

## Error Notifications

**Arzel Pro app dashboard with an invalid call**

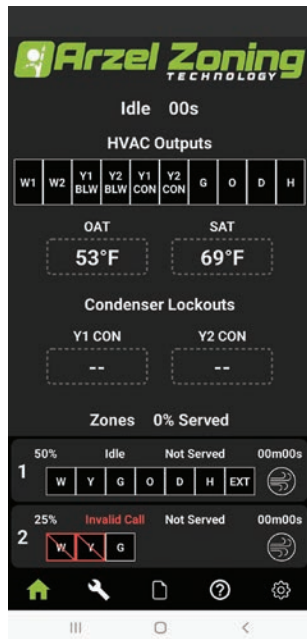

**Arzel Pro app dashboard with sensor error**

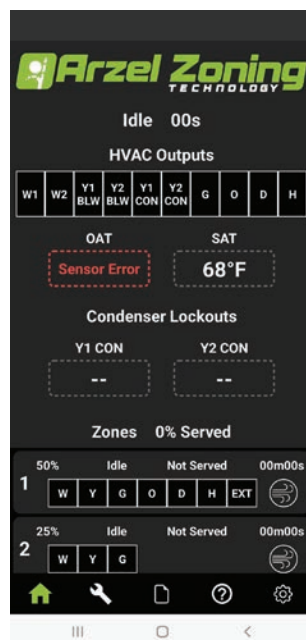

### Invalid Calls

If the Pro Panel receives an input from a zone's thermostat that does not correspond to a call, then it will display the text "Invalid Call" in the box for that zone. Invalid calls indicate that there is an issue with the wiring or configuration of the zone's thermostat. The most common invalid call occurs when a standard heat/cool thermostat energizes W (heat) and Y (cooling) at the same time.

### Sensor Errors

Whenever the LAT or OAT sensor reads a value outside of the possible range, the text "Sensor Error" will appear on the dashboard instead of the temperature value. While there is a sensor error, the Pro Panel will ignore that sensor entirely. Settings related to the operation of that sensor will not affect system operation until the error is resolved.

A sensor error usually indicates that there is an issue with the sensor wiring, or a sensor fault.

# System Commissioning

To ensure the Arzel Pro Panel zoning system operates properly after completing all installation and system configuration steps, please follow the procedures below for commissioning the system.

## Damper Verification

1. Set all thermostats to the OFF mode and all thermostat fan switches to AUTO.
2. Turn the HVAC system and the Pro Panel system power switches ON.
3. Turn the zone 1 thermostat fan switch ON. The fan in the HVAC system will turn on. Check the airflow at all registers to determine that only zone 1 dampers are open and all other dampers are closed.
4. Follow the above procedure for all other zones.

## Bypass Adjustment and Checkout

1. Configure the system. Set the Zone Weights, W2 Zone Weight Threshold, and Y2 Zone Weight Threshold as appropriate.
2. Initiate the highest expected blower operation with a heating or cooling call. Initiate the call in the smallest zone capable of turning on the HVAC equipment.
3. Adjust the bypass closed and have the customer determine if the air delivery noise is objectionable. The customer must be informed that elevated air delivered into the smallest zone is critical to effective system operation when a single zone calls.
4. Adjust the bypass in small increments until the objectionable noise is eliminated. (Bypass is only done to eliminate objectionable air noise; consult the homeowner to determine their needs.)
5. If the blower is running in low stage, initiate calls in other small zones until the blower upstages. Re-verify the bypass position with equipment blower operating at highest capacity.

## Heating Checkout

1. Set all thermostats to the OFF position.
2. Enable demo mode in the Arzel Pro mobile app settings screen (gear icon).
3. Remove the supply air temperature (SAT) sensor from the supply ductwork.
4. Initiate a call for heat on zone 1, a signal for stage 1 heat will be sent to the HVAC equipment. The HVAC outputs will appear on the Arzel Pro mobile app dashboard (house icon).
5. Initiate a call in a second zone that will raise the served zone weight above the W2/Y2 Zone Weight Threshold. Heating will stage up and high-stage outputs will be sent to the HVAC equipment. The mobile app dashboard will update.
6. Allow the unit to continue to run in heating mode until it reaches the maximum heating stage.
7. If not proceeding with the Cooling Checkout, reinstall the supply air temperature (SAT) sensor and disable demo mode in the Arzel Pro mobile app settings screen (gear icon).

*(system commissioning continues on the next page)*

### Cooling Checkout

1. Set all thermostats to the OFF position
2. Enable demo mode in the Arzel Pro mobile app settings screen (gear icon).
3. Remove the supply air temperature (SAT) sensor from the supply ductwork.
4. Initiate a call for cooling from any zone.
5. The Y1 Condenser, Y1 Blower, G and optional O signal will appear on the display screen and send a first stage cooling signal to the blower and condenser.
6. Initiate a call in a second zone to raise the served zone weight above the Y2 Zone Weight Threshold . A Y2 signal to the blower and condenser will appear on the app dashboard. Cooling will ramp up to second stage.
7. Turn the thermostats to OFF and re-install the Supply Air Temperature (SAT) sensor into the supply duct.
8. Disable demo mode in the Arzel Pro mobile app settings screen (gear icon).

### Balance Point Checkout (Dual Fuel Systems)

1. Raise the balance point temperature setting above the outdoor air temperature or submerge the outdoor air temperature sensor in a cup of ice to lower the reading.
2. Initiate a call for heat in any zone.
3. The W1 signal will appear on the mobile app dashboard and a call for the backup heating equipment will start.
4. Turn zone thermostat off and allow the heating equipment to cycle off.

### Customer Orientation

1. In an effort to eliminate end user misunderstandings and potential call-backs, review the configuration parameters and explain how the system should be expected to function.
2. Go over thermostat locations and functions and advise on the most energy saving set-back settings (Setting back all zones during their unoccupied period will provide the best savings.)
3. If the zone 1 thermostat is equipped with an "Emergency Heat" mode explain when and how to use it. Explain the expected equipment operation in the "Emergency Heat" mode.

## Pro Panel Settings

To set up and configure the Pro Panel, follow the instructions on page 15 to connect the Pro Panel to a tablet or mobile device. If the Pro Panel is being configured for the first time, follow the instructions in the Arzel Pro mobile app to proceed to the setup wizard. To change the settings on an installed Pro Panel system, tap the wrench icon and select the parameter to change it.

The Arzel Pro mobile app provides preset default configurations for the most common types of HVAC equipment. When using a default configuration, always review the settings before attempting to engage any HVAC equipment. Zone weights and zone weight thresholds cannot be set automatically, and must be configured manually.

Visit [www.arzelzoning.com/pro-panel](http://www.arzelzoning.com/pro-panel) to see a list of the default settings for each equipment type.

Parameter	Description	Options
HVAC Equipment Type	Select the type of HVAC equipment connected to the Pro Panel.	<ul style="list-style-type: none"> <li>● Conventional</li> <li>● Heat Pump Only</li> <li>● Heat Pump with Electric Backup</li> <li>● Heat Pump with Fossil Fuel Backup</li> </ul>
Reversing Valve Energized	<p>For heat pump systems, select the mode in which the reversing valve is energized.</p> <p><b>Note:</b> Heat pump thermostats connected at zone 1 must be configured to energize the reversing valve as required by the condenser. If the outdoor condensing unit requires a "B" signal when heating, then heat pump thermostats connected at zone 1 must energize "B" in heating. This is different than older models of Arzel Zoning systems.</p>	<ul style="list-style-type: none"> <li>● Cooling (O)</li> <li>● Heating (B)</li> </ul>
Package Unit or Split System	<p>Select The HVAC equipment type.</p> <p>Select split system if there is a separate indoor unit and outdoor unit and they have separate Y1/Y2 contacts. Otherwise, select package unit.</p>	<ul style="list-style-type: none"> <li>● Package Unit</li> <li>● Split System</li> </ul>
Heat/Backup Heat Controls Fan	<p>Select "Yes" if the heat/backup heat controls the fan.</p> <p>If the heat/backup heat requires G to run the fan, select "No". Otherwise, select "Yes".</p>	<ul style="list-style-type: none"> <li>● Yes</li> <li>● No</li> </ul>
Condenser Stages	<p>Set the number of heat pump or A/C stages that the Pro Panel will control.</p> <p>If the Condenser Y1 and Condenser Y2 outputs are both connected to the outdoor unit, select two-stage. Otherwise, select single-stage.</p>	<ul style="list-style-type: none"> <li>● Single-stage</li> <li>● Two-stage</li> </ul>

## Pro Panel Settings *(continued)*

Parameter	Description	Options
Blower Stages	Set the number of blower stages that the Pro Panel will control.  If the Blower Y1 and Blower Y2 outputs are both connected to the indoor unit, select two-stage. Otherwise, select single-stage.	<ul style="list-style-type: none"> <li>● Single-stage</li> <li>● Two-stage</li> </ul>
Heat/Backup Heat Stages	Set the number of indoor unit heat stages that the Pro Panel will control.  If the W1 and W2 outputs are both connected to the indoor unit, select two-stage. Otherwise, select single-stage.	<ul style="list-style-type: none"> <li>● Single-stage</li> <li>● Two-stage</li> </ul>
Zone 1 Thermostat Type	Set the type of thermostat that will be connected at zone 1.  For heat pump systems, either a heat pump thermostat or a heating/cooling thermostat can be connected at zone 1. All other zones must use a heating/cooling stat.  <b>Note:</b> Heat pump thermostats are never required by the Pro Panel, even when controlling heat pump systems.	<ul style="list-style-type: none"> <li>● Heating/Cooling</li> <li>● Heat Pump</li> </ul>
Supply Air Temperature Sensor	Enable or disable the Supply Air Temperature (SAT) sensor.  The SAT sensor monitors the temperature of the air in the supply plenum to provide staging control, high temperature limits, and freeze protection.  <b>Note:</b> Enabling the SAT sensor is always recommended. Disabling the SAT sensor removes all associated features, including the features used to protect HVAC equipment.	<ul style="list-style-type: none"> <li>● Yes</li> <li>● No</li> </ul>
Outdoor Air Temperature Sensor	Enable or disable the Outdoor Air Temperature (OAT) sensor.  The OAT sensor monitors the ambient air temperature to provide equipment lockouts and a balance point for heat pump systems.	<ul style="list-style-type: none"> <li>● Yes</li> <li>● No</li> </ul>
EXT Input During A2L Leak	An A2L refrigerant detection system can be wired to the R and EXT terminals at zone 1.  Choose the voltage present at EXT during a leak.	<ul style="list-style-type: none"> <li>● Disabled</li> <li>● 24 VAC</li> <li>● 0 VAC</li> </ul>
W2 Zone Weight Threshold	Set the percentage of ductwork that must be available for W2 to energize.  If there are not enough open zones to meet this threshold, W2 will be locked out.	30% - 100%
Y2 Zone Weight Threshold	Set the percentage of ductwork that must be available for Blower Y2 and Condenser Y2 to energize.  If there are not enough open zones to meet this threshold, Blower Y2 and Condenser Y2 will be locked out.	30% - 100%

## Pro Panel Settings (continued)

Parameter	Description	Options
Zone Weight	<p>Set the relative weight of each zone. A zone's weight approximately represents the percentage of ductwork assigned to that zone. <b>The sum of zone weights does not need to equal 100%.</b></p> <p>Individual zones can be configured so that they cannot engage the HVAC equipment when calling alone. Configuring a zone this way can prevent the equipment from engaging when there is not enough open ductwork</p>	<ul style="list-style-type: none"> <li>● 10% - 90%</li> <li>● No (the zone cannot engage the HVAC equipment when calling alone)</li> </ul>
Conflicting Call Priority	<p>Select how the system will handle simultaneous heating and cooling calls.</p> <ul style="list-style-type: none"> <li>● <b>Automatic:</b> Heating and cooling run on a first come, first served basis</li> <li>● <b>Prioritize Heating:</b> Heating calls can override cooling calls</li> <li>● <b>Prioritize Cooling:</b> Cooling calls can override heating calls</li> <li>● <b>Zone Weight:</b> Heating and cooling are served based on the total weight of calling zones. If a greater weight is calling for heating, then heating will be served, and vice versa.</li> </ul>	<ul style="list-style-type: none"> <li>● Automatic</li> <li>● Prioritize Heating</li> <li>● Prioritize Cooling</li> <li>● Zone Weight</li> </ul>
Conflicting Call Time	<p>Set the timer for simultaneous heating and cooling calls. The system will use this timer to determine how long to serve one function before switching over to the other.</p>	10 minutes - 45 minutes
Secondary Purge Time	<p>Set the end-of-cycle delay that allows all of the dampers to open at the end of a call. This delay allows for a soft start the next time dampers should close.</p> <p>To calculate the recommended number of seconds for the secondary purge time, multiply the total number of dampers by five.</p>	0 seconds - 180 seconds
Heat Pump SAT High Limit	<p>Set the supply air temperature high limit for safe heat pump operation.</p> <p>If the SAT sensor reads a value above this limit, the heat pump will stage down.</p>	<ul style="list-style-type: none"> <li>● 100°F - 140°F</li> <li>● Disable</li> </ul>
Balance Point OAT	<p>Set the changeover temperature for heat pump systems that have a backup heat source. The heat pump will not engage below this outdoor temperature. The balance point can be disabled to allow the heat pump to run at low temperatures.</p>	<ul style="list-style-type: none"> <li>● 0°F - 55°F</li> <li>● Disable</li> </ul>
Heating SAT Target	<p>Set the supply air temperature (SAT) required for comfort while heating. If the SAT does not reach this value, heating will stage up.</p>	<ul style="list-style-type: none"> <li>● 70°F - 130°F</li> <li>● Disable</li> </ul>

## Pro Panel Settings (continued)

Parameter	Description	Options
Heat Pump Heating Stage-up Time	<p>Set the minimum amount of time the heat pump runs in stage 1 before staging up to stage 2. This timer does not apply to single-stage heat pumps.</p> <p>When this timer expires, the system uses the Heating SAT Target to determine if the heat pump will stage up. If the Heating SAT Target is disabled, the heat pump will always stage up when this timer expires.</p> <p>Default: 10 minutes</p>	3 minutes - 60 minutes
Heat Pump to Backup Heat Stage-up Time	<p>Set the minimum amount of time the heat pump runs in its highest stage before staging up to the backup heat.</p> <p>The system uses the Heating SAT target to determine if the heat pump will stage up.</p>	3 minutes - 60 minutes
Heating/Backup Heat SAT High Limit	<p>Set the supply air temperature (SAT) high limit for the indoor unit heat source.</p> <p>If the SAT sensor reads a value above this limit, the indoor unit heat source will stage down.</p>	<ul style="list-style-type: none"> <li>● 100°F - 180°F</li> <li>● Disable</li> </ul>
Backup Heat OAT Lockout	<p>Set the backup heat OAT lockout; the backup heat will not engage above this outdoor temperature.</p> <p>Default: 30°F</p>	<ul style="list-style-type: none"> <li>● 0°F - 55°F</li> <li>● Disable</li> </ul>
Heating/Backup Heat Stage-up Time	<p>Set the minimum amount of time the heating/the backup heat source runs before staging up.</p> <p>Default: 10 minutes</p>	3 minutes - 60 minutes
Cooling SAT Low Limit	<p>For freeze protection, set the supply air temperature low limit for safe cooling operation.</p> <p>If the SAT sensor reads a value below this limit, cooling will stage down.</p> <p>Default: 42°F</p>	<ul style="list-style-type: none"> <li>● 34°F - 46°F</li> <li>● Disable</li> </ul>
Cooling OAT Lockout	<p>Set the cooling OAT lockout; cooling will not engage below this outdoor temperature.</p> <p>This value should be set based on the manufacturer recommended lowest ambient temperature for cooling operation.</p> <p>Default: 50°F</p>	<ul style="list-style-type: none"> <li>● 20°F - 60°F</li> <li>● Disable</li> </ul>
Cooling SAT Target	<p>Set the target supply air temperature during cooling. If the SAT does not reach this value, cooling will stage up.</p> <p>Default: 55°F</p>	<ul style="list-style-type: none"> <li>● 35°F - 60°F</li> <li>● Disable</li> </ul>

## Pro Panel Settings *(continued)*

Parameter	Description	Options
Cooling Stage-up Time	<p>Set the minimum amount of time cooling runs before staging up. When this timer expires, the system uses the Cooling SAT Target to determine if cooling will stage up.</p> <p>If the Cooling SAT Target is disabled, cooling will always stage up when this timer expires.</p> <p>Default: 10 minutes</p>	3 minutes - 60 minutes
Dehumidification Features	<p>Enable or disable dehumidification features.</p> <p>If dehumidification features are enabled the system can:</p> <ul style="list-style-type: none"> <li>● Use the D terminals to control a dehumidifier</li> <li>● Cycle low stage condenser on and off to provide dehumidification</li> </ul>	<ul style="list-style-type: none"> <li>● Enable</li> <li>● Disable</li> </ul>
Condenser Dehumidification Cycle	<p>Set the system to cycle the condenser to provide dehumidification.</p> <p>Set how long the condenser will run during each cycle.</p> <p>When the dehumidification condenser cycle is enabled, a call for dehumidification will turn low-stage condenser on and off, open all dampers, and run low stage fan.</p> <p>Default: Disable</p>	<ul style="list-style-type: none"> <li>● 5 minutes - 15 minutes</li> <li>● Disable</li> </ul>
Humidification Features	<p>Enable or disable humidification features.</p> <p>If humidification features are enabled, the system can use the H terminals to control a humidifier.</p>	<ul style="list-style-type: none"> <li>● Enable</li> <li>● Disable</li> </ul>
Standalone Humidification	<p>Select whether the humidifier can run at any time or only with heating.</p> <p>Select "Any Time" to allow the humidifier to run independently, the panel will output for G and H when a call for humidity is initiated at zone 1 Inputs.</p> <p>If set to "With Heating" the panel will only output for H if a call for heat is being served to any zone.</p>	<ul style="list-style-type: none"> <li>● Any Time</li> <li>● With Heating</li> </ul>

## Setup Worksheet

Fill in the right columns with the settings that you use and record the setup date.

Function	Options	Initial Setup/Date	Adjusted Setup/Date
HVAC Equipment Type	Conventional, Heat Pump Only, Heat Pump with Electric Backup, Heat Pump with Fossil Fuel Backup		
Reversing Valve Energized	Cooling (O), Heating (B)		
Package Unit or Split System	Package Unit, Split System		
Heat/Backup Heat Controls Fan	Yes, No		
Condenser Stages	Single-stage, Two-stage		
Blower Stages	Single-stage, Two-stage		
Heat/Backup Heat Stages	Single-stage, Two-stage		
Zone 1 Thermostat Type	Heat Pump, Heating/Cooling		
Supply Air Temperature Sensor	Yes, No		
Outdoor Air Temperature Sensor	Yes, No		
EXT Input During A2L Leak	Disabled, 24 VAC, 0 VAC		
W2 Zone Weight Threshold	30% - 100%		
Y2 Zone Weight Threshold	30% - 100%		
Zone Weights	10% - 90%, No		
Conflicting Call Priority	Automatic, Heating, Cooling, Zone Weight		
Conflicting Call Time	10 minutes - 45 minutes		
Secondary Purge Time	0 seconds - 180 seconds		
Heat Pump SAT High Limit	100°F - 140°F, Disable		
Balance Point OAT	0°F - 55°F, Disable		
Heating SAT Target	70°F - 130°F, Disable		
Heat Pump Heating Stage-up Time	3 minutes - 60 minutes		
Heat Pump to Backup Heat Stage-up Time	3 minutes - 60 minutes		
Heating/Backup Heat SAT High Limit	100°F - 180°F, Disable		
Backup Heat OAT Lockout	0°F - 55°F, Disable		
Heating/Backup Heat Stage-up Time	3 minutes - 60 minutes		
Cooling SAT Low Limit	34°F - 46°F, Disable		
Cooling OAT Lockout	20°F - 60°F, Disable		
Cooling SAT Target	35°F - 60°F, Disable		
Cooling Stage-up Time	3 minutes - 60 minutes		
Dehumidification Features	Enable, Disable		
Condenser Dehumidification Cycle	5 minutes - 15 minutes, No		
Humidification Features	Enable, Disable		
Standalone Humidification	Any Time, With Heating		

# EzySlide Damper Installation



**1. Apply the template** with the airflow arrow pointed towards the register.



**2. Cut out the triangle.** Drill a 3/4-inch hole at each of the 3 corners and connect the holes with your snips.



**3. Insert the damper.** Hold it in the closed position, and insert the blade at the wide end of the triangle.



**4. Twist into position.** After the blade is inserted, rotate the damper 90° with the tubing port facing the main duct.



**5. Fasten with zip screws.** Secure the damper at two opposing corners. Add the other two screws. Tighten all four screws to just seal the gasket.



**6. Attach the air line.** Cut a 3/4-inch section out of the "home-run tube" for that zone and insert a tee to connect to the damper.



**7. Finished!** If the tubing looks neat and well organized, the workmanship appears worthy of the investment.

## Rectangular EzySlide Install

Cut out a rectangle with the inside dimensions of the gasket. Align the damper blade from corner to corner and slide it into the opening. Turn damper to align with the duct, and fasten with screws.

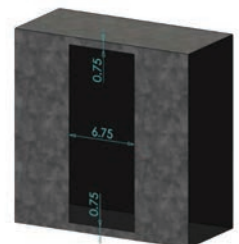

# Arzel Warranty

## Warranty Information

Limited Lifetime Warranty on Panel & Dampers if warranty information is submitted to Arzel Zoning Technology, Inc. for Limited Lifetime Warranty Coverage within 90 days of installation.

The Panel serial number is required when entering warranty information. This serial number is located on a sticker inside the panel box. See photos below for possible locations.

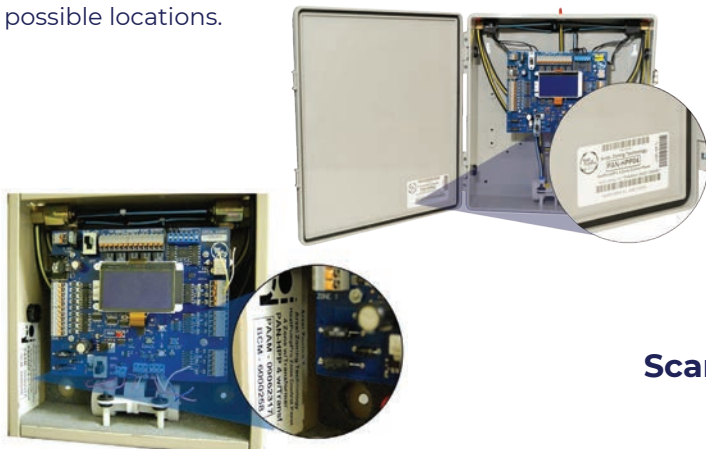

## Warranty Procedure

To receive an RMA, technicians must call while on site (no call-no warranty). Warranties returned to distributors without prior authorization may be denied or subject to 20% processing fee.

1. Call 800-611-8312 while on the job-site to diagnose failed parts and continue the warranty process.
2. Any diagnosis of failed parts must be verified by Arzel Technical Support to receive an RMA (Return Material Authorization).
3. All warranty claims must include the serial number of the panel (see image above).
4. Arzel will ship warranty parts directly to licensed contractors via UPS Ground. (Next day air is available at an additional cost.)
5. Arzel Technical Support is available 7 days a week from 8am - 9pm EST.

Scan within 90 days of installation to register this product for the limited lifetime warranty.



# Bypass Sizing Charts

## Trunk Dampers

(Diameter of a round bypass duct, in inches)

Blower Tonnage

	2	2.5	3	3.5	4	5
100	8	10	10	12	12	14
200	8	10	10	12	12	14
300	*	*	8	10	10	12
400	none	*	*	8	10	12
500	none	none	*	*	8	10
600	none	none	none	*	*	10
700	none	none	none	none	*	8
800	none	none	none	none	none	*
900	none	none	none	none	none	*
1000	none	none	none	none	none	none

**none:** no bypass required    **\*** borderline case; check other bypass sizing considerations

## Branch Dampers

(Diameter of a round bypass duct, in inches)

Blower Tonnage

	2	2.5	3	3.5	4	5
100	*	8	8	10	10	12
200	*	*	8	8	10	10
300	none	none	*	*	8	10
400	none	none	none	*	*	8
500	none	none	none	none	*	8
600	none	none	none	none	none	*
700	none	none	none	none	none	none
800	none	none	none	none	none	none
900	none	none	none	none	none	none
1000	none	none	none	none	none	none

**none:** no bypass required    **\*** borderline case; check other bypass sizing considerations

## Bypass Guidelines

- Calculate bypass from low-stage CFM tonnage when combining 2-stage split systems with the Pro Panel, HeatPumpPro, or GTPro and using zone weight
- Keep the bypass as small as possible.
- Bypass should be 6-8 feet from HVAC system when possible.

## Other Bypass Sizing Considerations

**flex duct:** downsize the bypass by one size due to increased friction loss inherent in flex duct

**distant zones:** Duct length greater than 200 feet may require a one-size decrease due to increased friction loss

**close zones:** duct length less than 50 feet may require a one-size increase.

**special purpose zones:** usage patterns may require an increase in bypass size